



L5P Duramax EGR Filtration System

INSTALLATION MANUAL

Part Number: EGRC20

**DURAMAX L5P
2020-2024**





www.fassegrsolutions.com

(866) 769.3747

**Thank you for choosing FASS, from
Diesel Performance Products, Inc.**

FASS specializes in building extremely high-quality fuel products. We have earned an unsurpassed reputation for excellence in our industry by using only the highest-quality American-made components. In order to support our American workers and our American economy, more than 98+ percent of our products are manufactured completely in the United States.

Of course, that dedication to excellence comes at a price, but it is important to remember that price does not dictate quality-quality dictates price! We will never compromise by using cheaper, foreign-made components, like so many of our competitors do.

Customer satisfaction is our top priority and we strive always to provide outstanding customer service. Our Research and Development department, in conjunction with our Dealer Support Department, continually searches for ways to improve quality, expand our product line, and provide superb support. Our exclusive ViP Network ensures that customers receive the proper products and support at the local level. The extended warranty is only available on products purchased from the network. There is no warranty on products not purchased outside the network.

IMPORTANT:

In order to qualify for the one year extended warranty, your product registration form and proof of purchase from an authorized dealer must be submitted to FASS EGR Solutions within 30 days of purchase. Failure to comply will void the warranty. We have the right to deny any warranty believed to be false, altered or purchased through an unauthorized or terminated dealer. A current list of authorized dealers can be found on our website, FASSEGRSolutions.com.

The complete conditions of the One Year of Warranty can be found in the back of this manual, and FASSEGRSolutions.com.

**For more information,
contact Technical Support:
Diesel Performance Products, Inc.
16234 State Hwy O.
Marthasville, MO 63357
636-433-5410**



WARNING!

This product has NO WARRANTY unless:

1. It has been purchased from an **Authorized or **ViP FASS Dealer**. If in doubt, check www.FASSEGRSolutions.com.**

2. It is registered within thirty (30) days of purchase.

Other conditions may apply. Please see full warranty information.

***NOTE:* Warranty is **void** if product was purchased below FASS website advertised pricing.**

ATTENTION!

Before you begin installation

Register for your Warranty ONLINE at

<https://www.fassegrsolutions.com/register-a-warranty/> No online access, call our **TECH**

Support at

1-866-769-3747

FOLLOW THESE STEPS TO ENSURE A SIMPLE, CORRECT INSTALLATION OF YOUR NEW EGR FILTRATION SYSTEM

- 1** Be sure the serial number on this installation manual matches that on the outside of the box.
- 2** Pay close attention to ALL WARNINGS
- 3** Read all instructions before starting installation of this product.
- 4** Inventory the package components. Notify the place of purchase immediately of any parts missing or damaged.
- 5** The installation recommendations contained herein are guidelines. Use good judgment and take into consideration your vehicles' accessories.
- 6** For best results in accuracy and efficiency (due to training, communication, and our relationship with our dealer network), we recommend a VIP FASS dealer for the installation. They are prepared to install the FASS EGR Filtration Systems with the most efficiency. If a situation or problem arises during the installation, the dealer is prepared to handle it. Diesel Performance Products, Inc. is not responsible for any installation mistakes.
- 7** If you have any questions or concerns that cannot be addressed with your dealer, email or call FASS.

**If any installation procedure is uncertain, contact FASS technical support.
Call customer service at 636-433-5410,
or send us an email: techsupport@FASSride.com
with the following information:**

Your name, address and daytime phone number Model

EGRC20

Last 6 digits of LOT number

Last 6 digits of vehicles' VIN

Date of purchase

Nature of Your Concern

Last 6 Digits of the

LOT Number



INSTALLATION MANUAL

EGRC20

- 1. Read all instructions before starting installation of this product!**
- 2. Installing the improper EGR Filter can cause severe engine damage.**
- 3. Secure vehicle from ROLLING!**
- 4. Consult vehicle's manufacturers' instructions concerning the electrical system before attempting any electrical connections.**
- 5. Be sure that the serial # on this installation manual matches that of the outside of the box.**
- 6. Keep debris from entering the internals of the system during installation.**
- 7. Wear safety glasses when operating power tools such as drills and grinders or when using a punch or chisel.**
- 8. Properly secure hoses to prevent chaffing.**

CONTENTS

NOTE: Owner's Manual available for download on our website, www.FASSride.com



Mounting Package Part Number:



**(THREE) 11116341
M8x30mm**



**11115733
M10x30mm**



CLA000105



(TWO) 1.5" V-Band Clamp

MOUNTING PACKAGE CONTENTS



GML5P01



GML5P04



**(TWO)
GM1719-001**



2024-GMBRCKT

1. Place the vehicle on suitable jack stands and remove the RH front wheel. Remove the mud flap and fender liner.

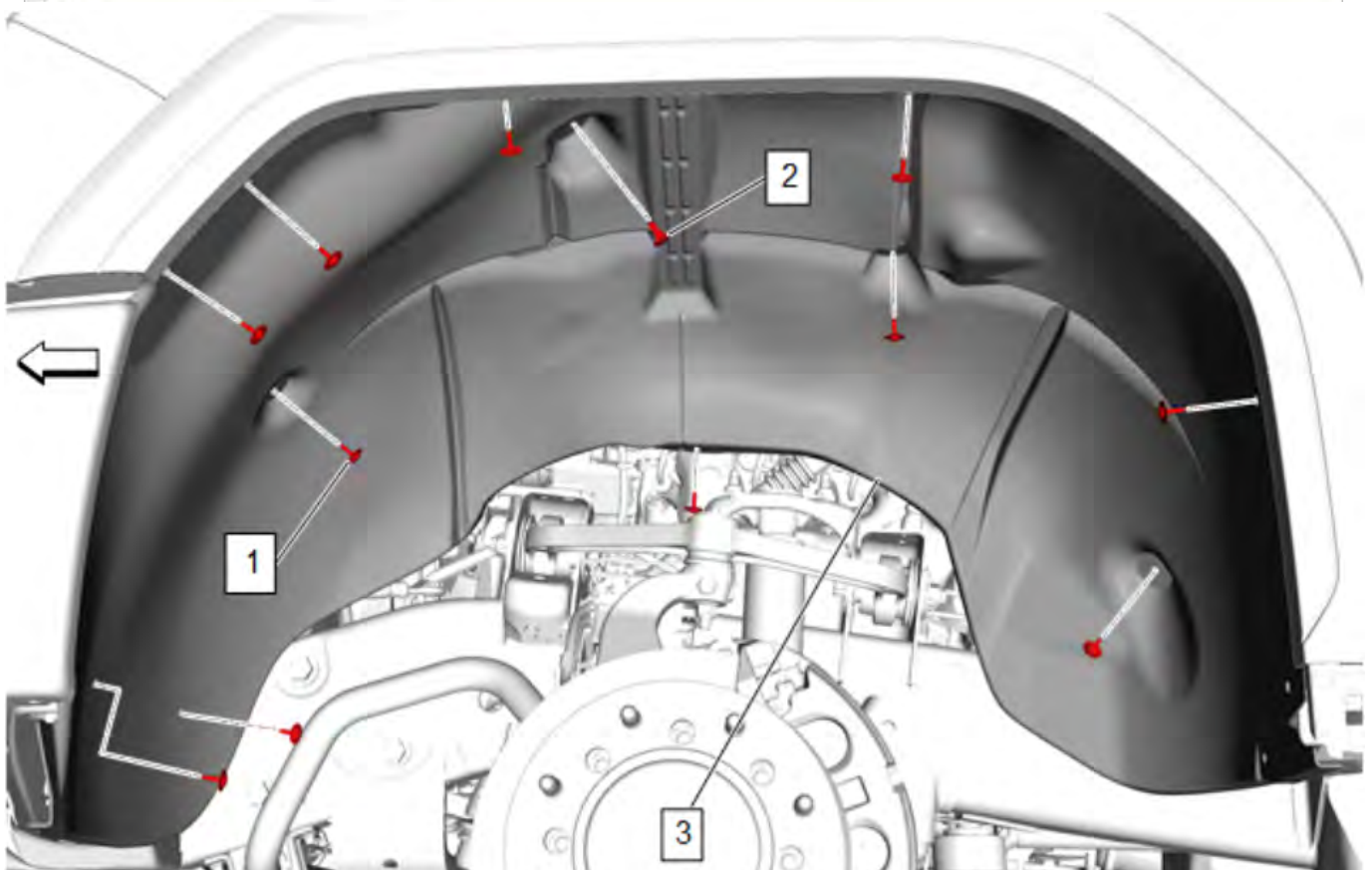
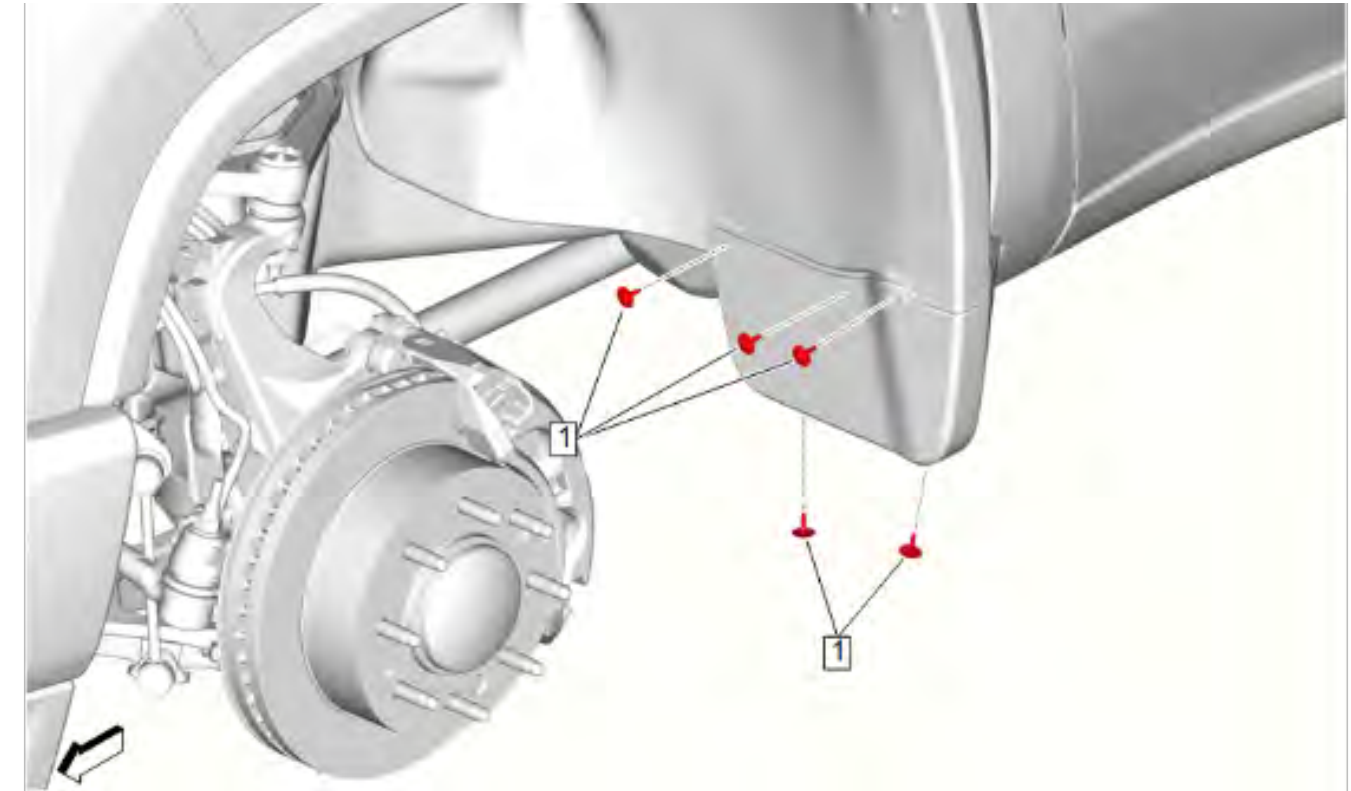

2. Remove the wire harness mounting bracket shown below.

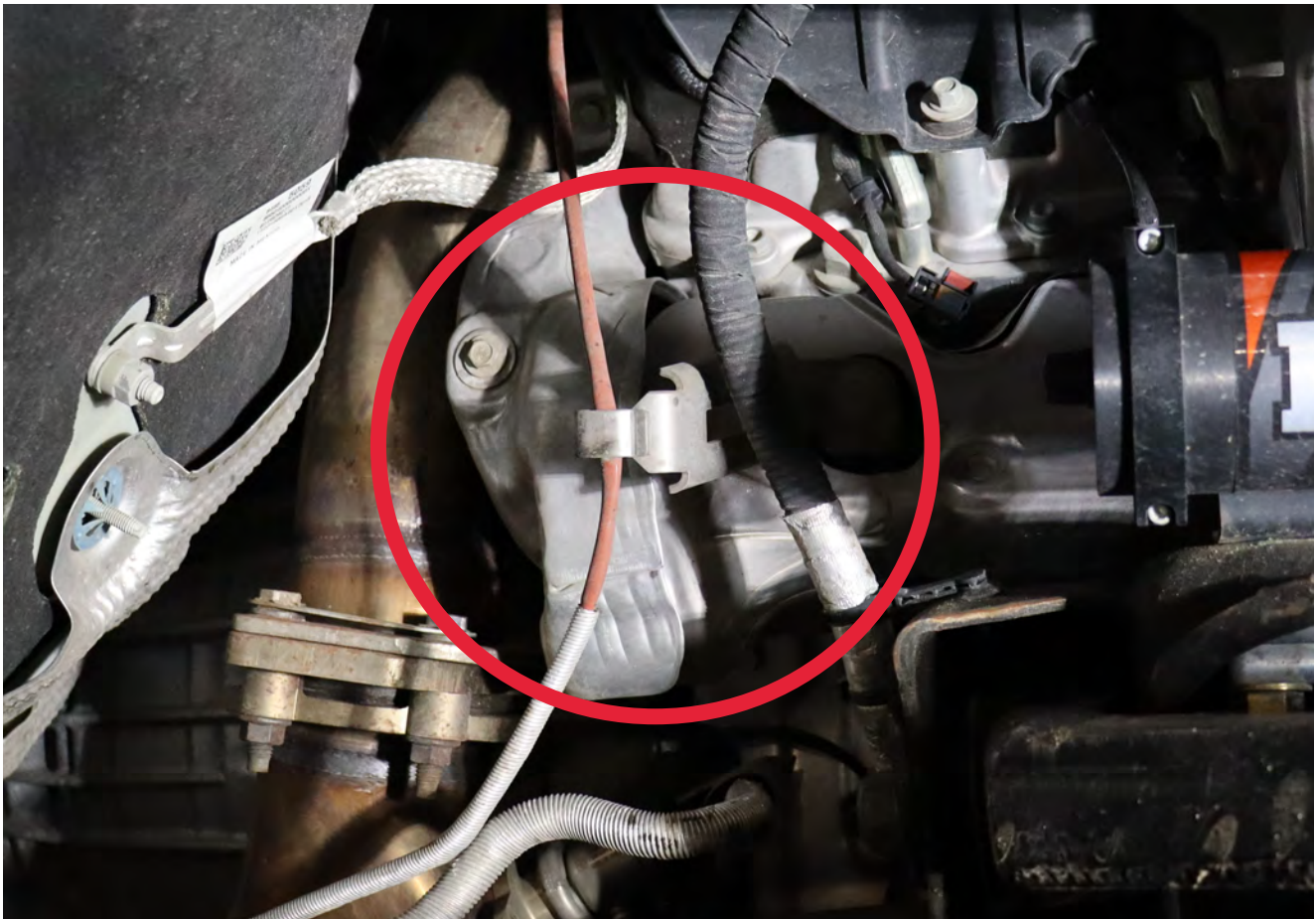

3. Remove the three EGR tube heat shield bolts, then remove the heat shield.

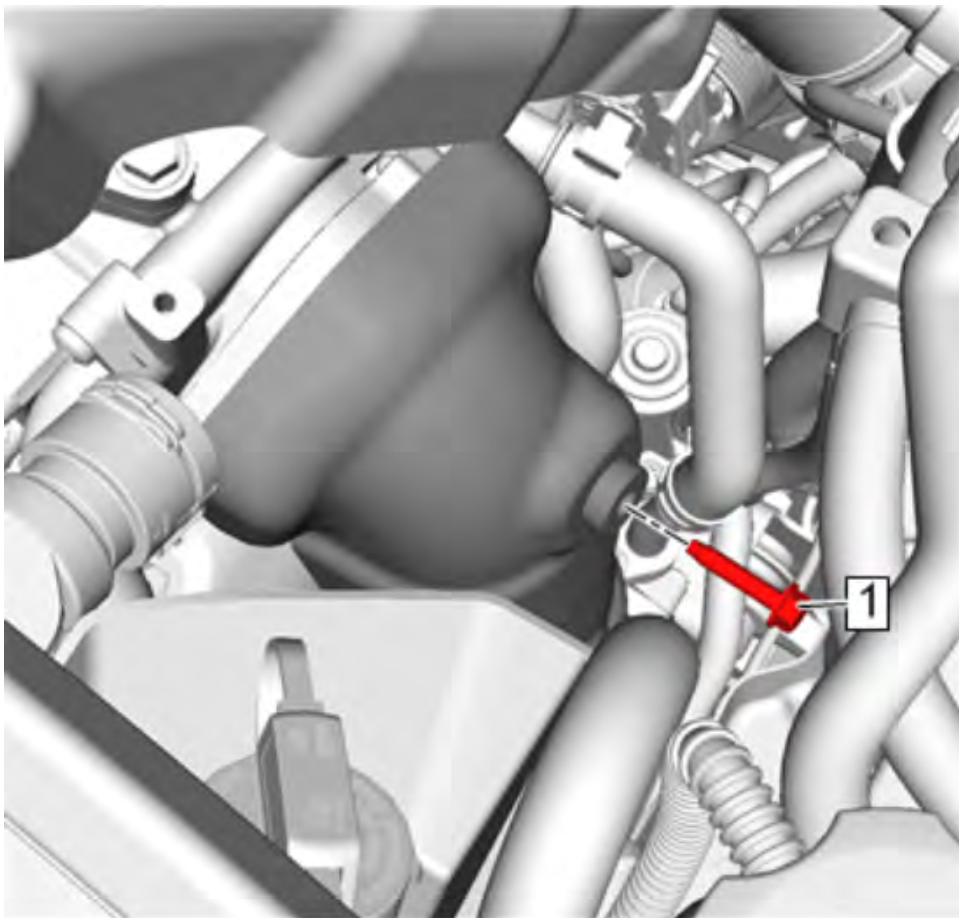
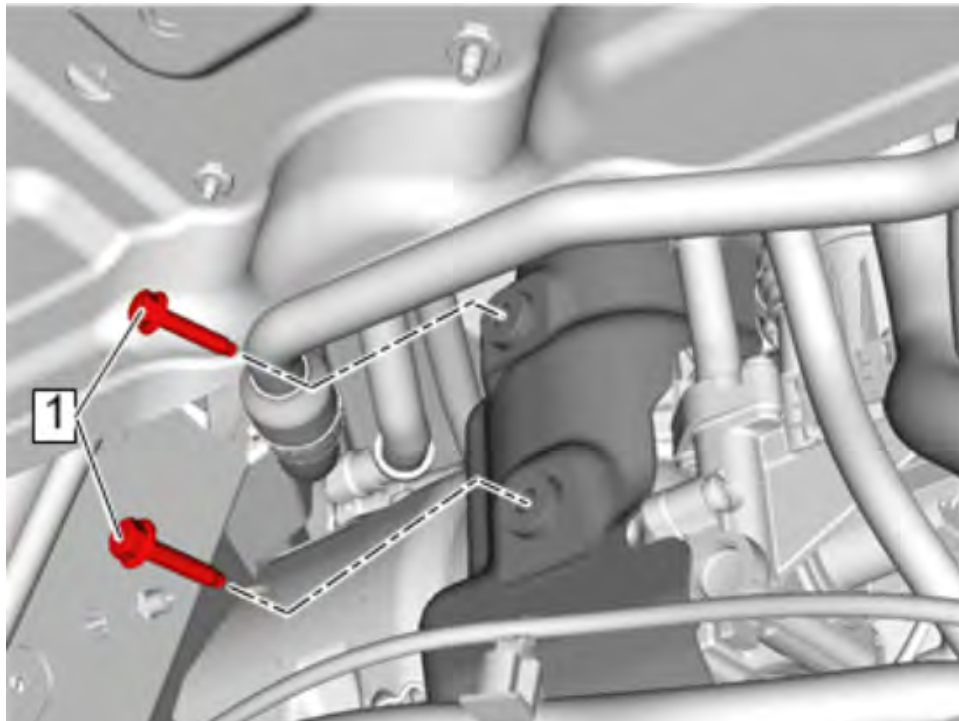

4. Remove the four EGR tube mounting bolts, then remove the EGR tube.

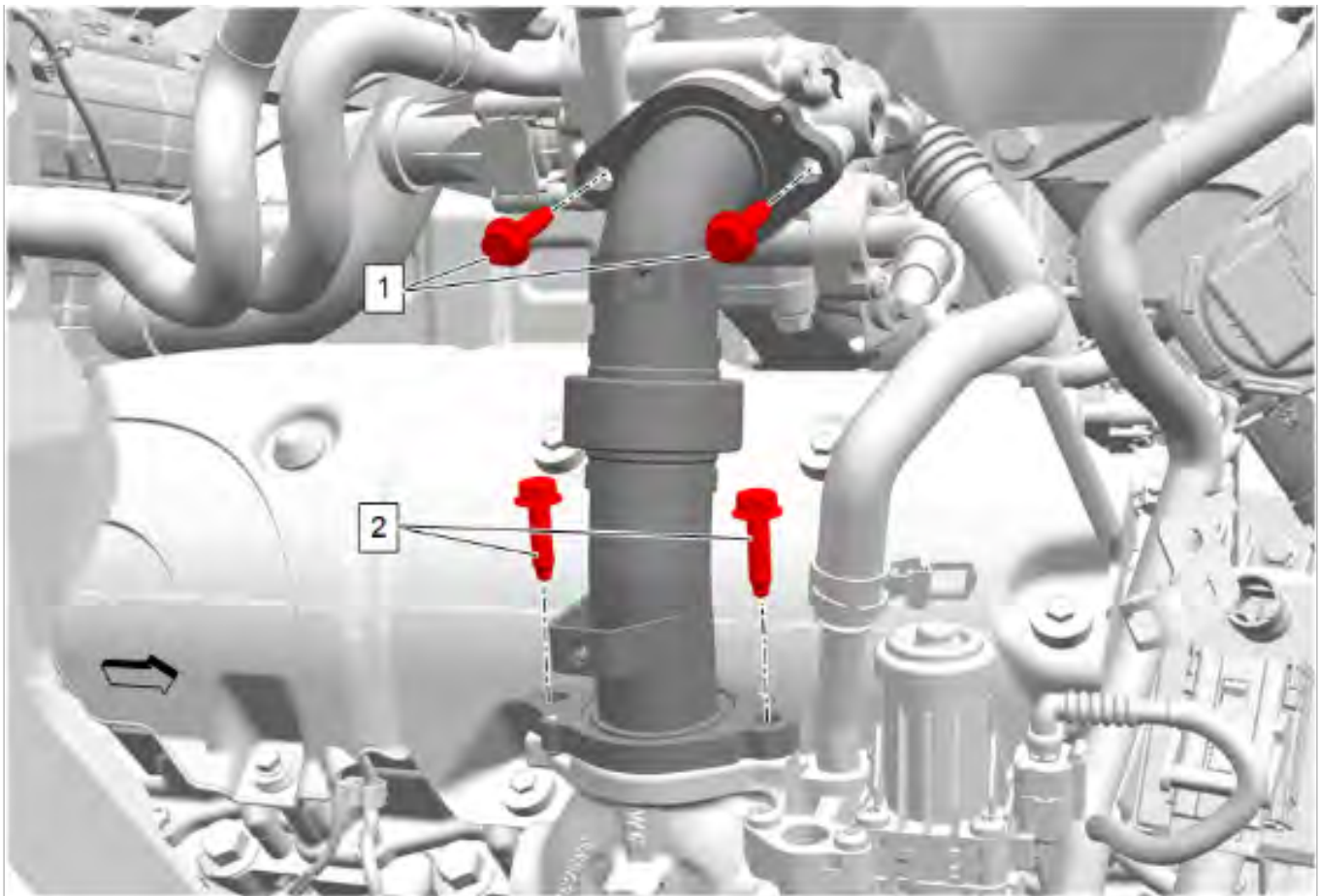

5. Install GML5P03 with two M8x30mm bolts PN. 11116341 and 2-bolt gasket as shown.

DO NOT TIGHTEN THE BOLTS AT THIS TIME!

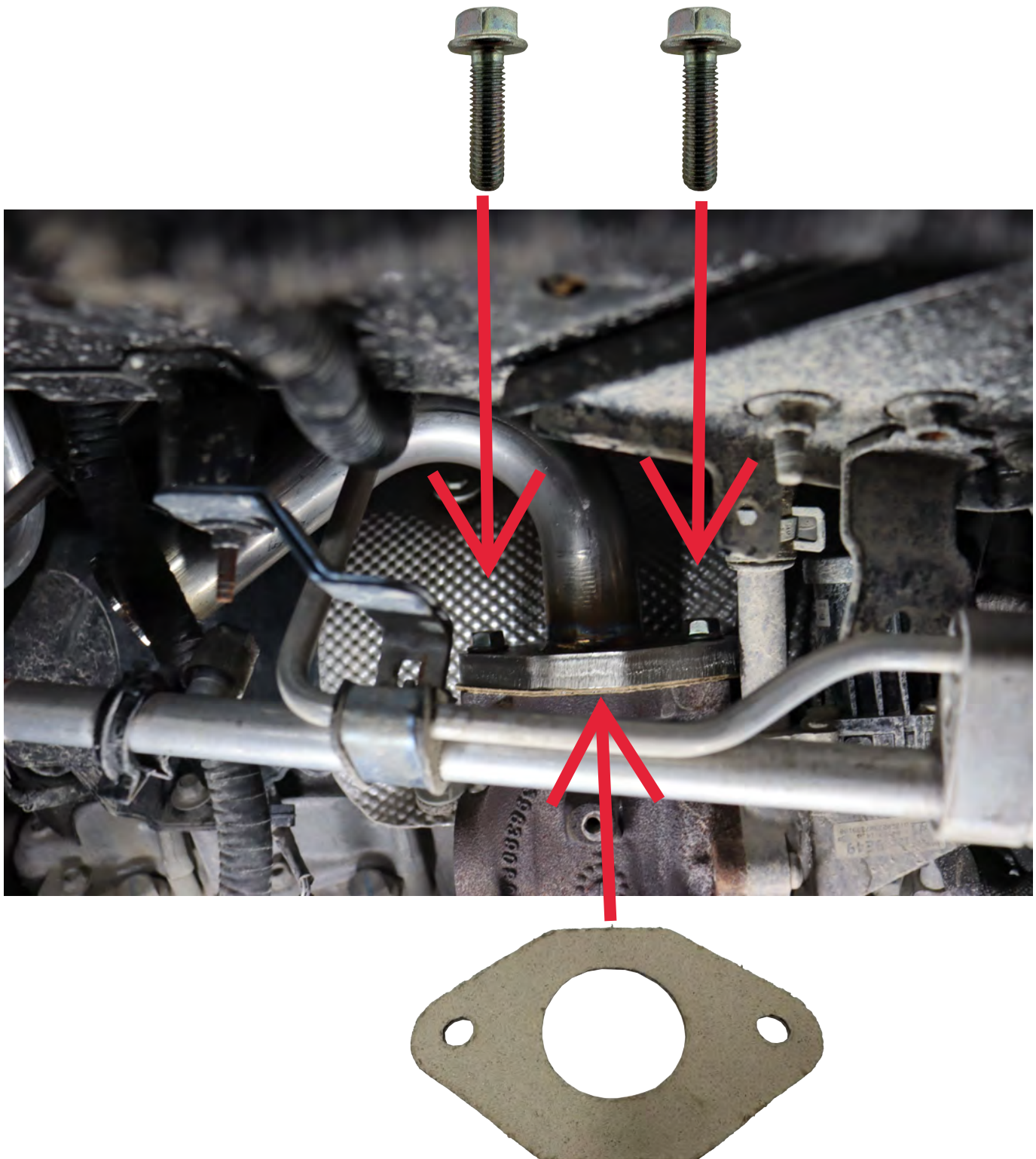

6. Paying close attention to the flow direction arrow on EGRF-3040, install onto GML5P03 with a supplied V-band clamp. Tighten the clamp just enough to keep the filter in place while still allowing some movement.

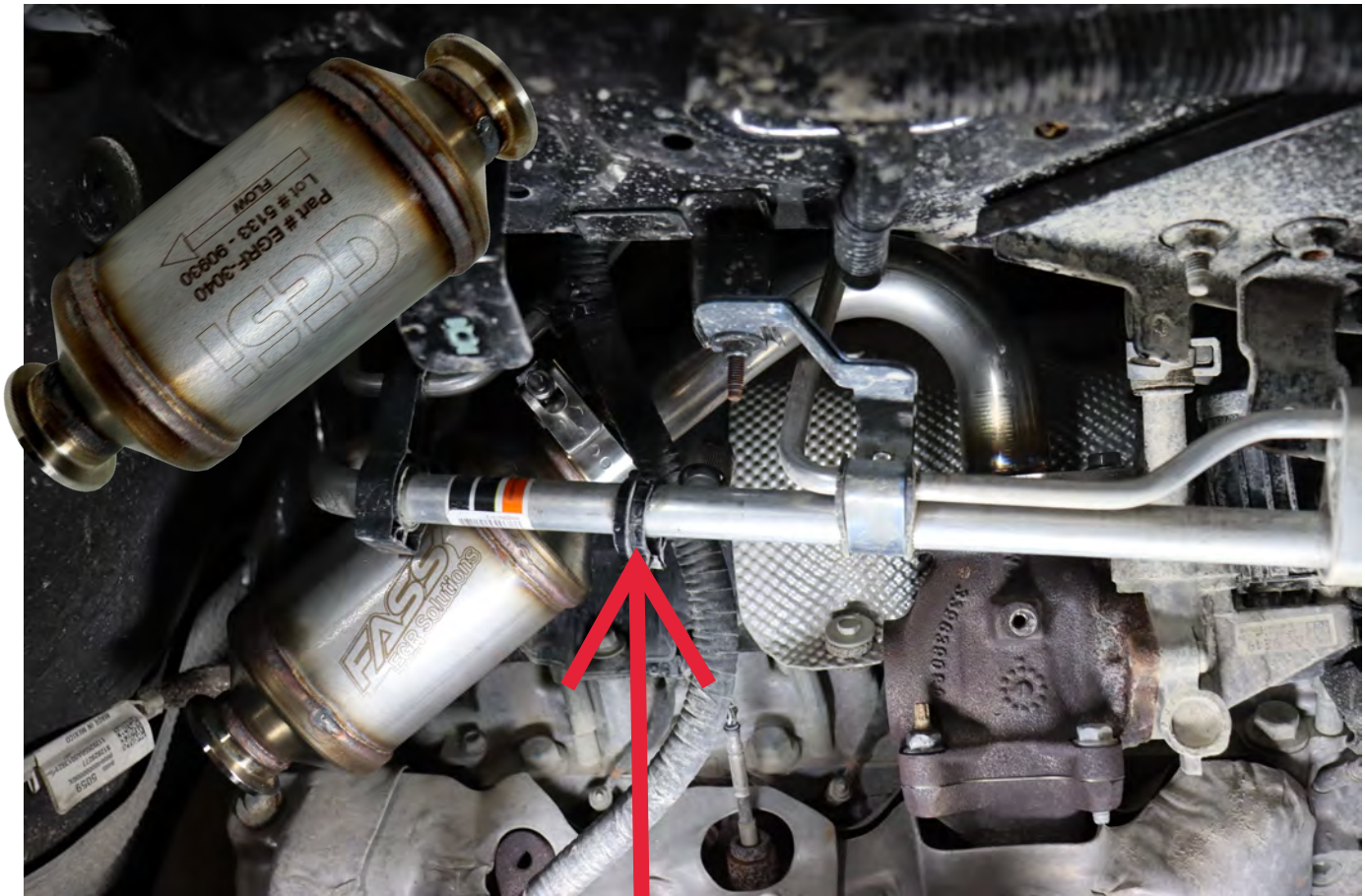

7. Install GML5P04 onto EGRF-3040 with a supplied V-band clamp. Tighten the clamp enough to keep the tube in place while still allowing some movement.

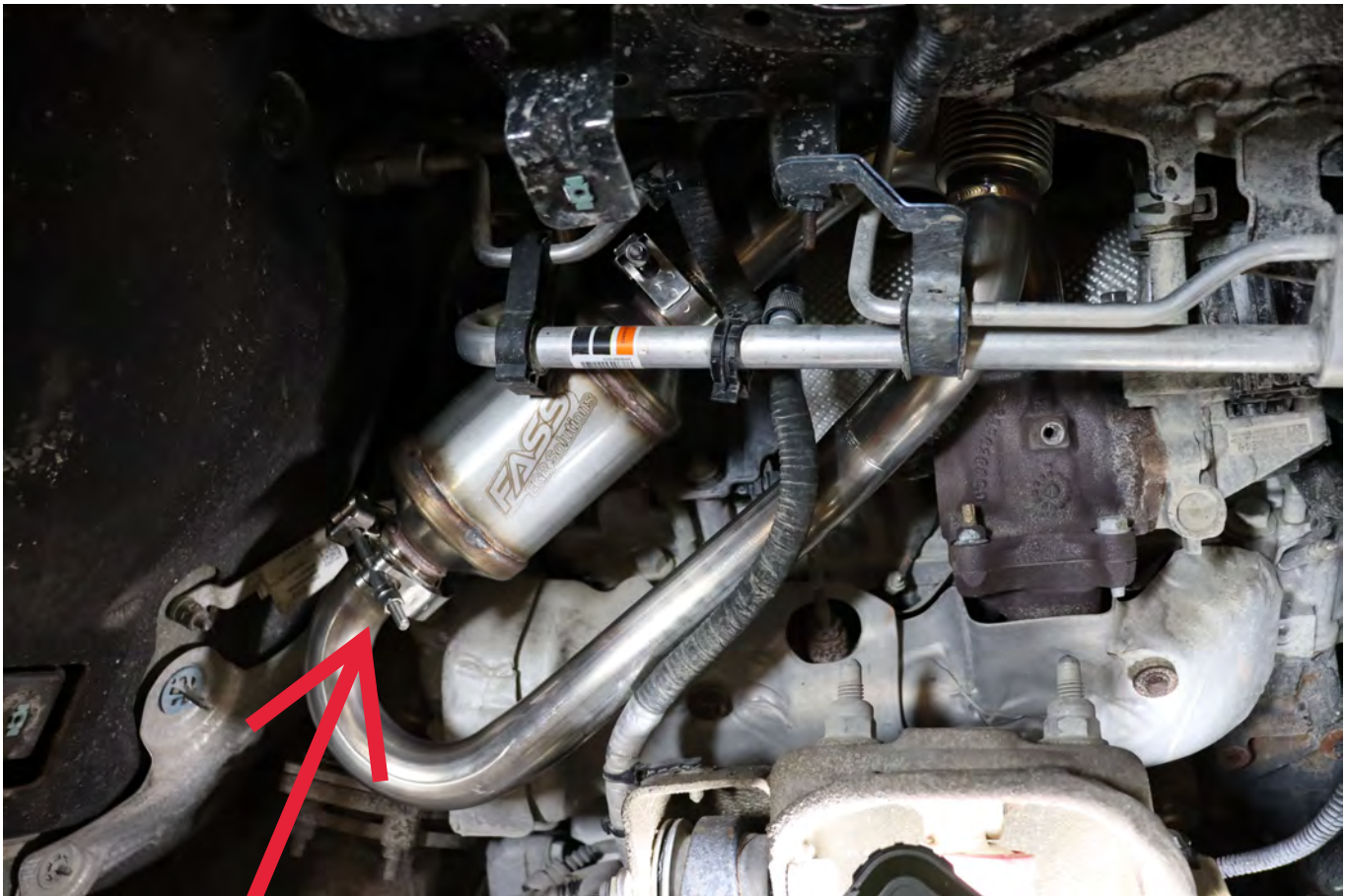

8. Loosely install the two M8x30mm bolts PN. 11116341 and 2-bolt gasket at the upper EGR port.

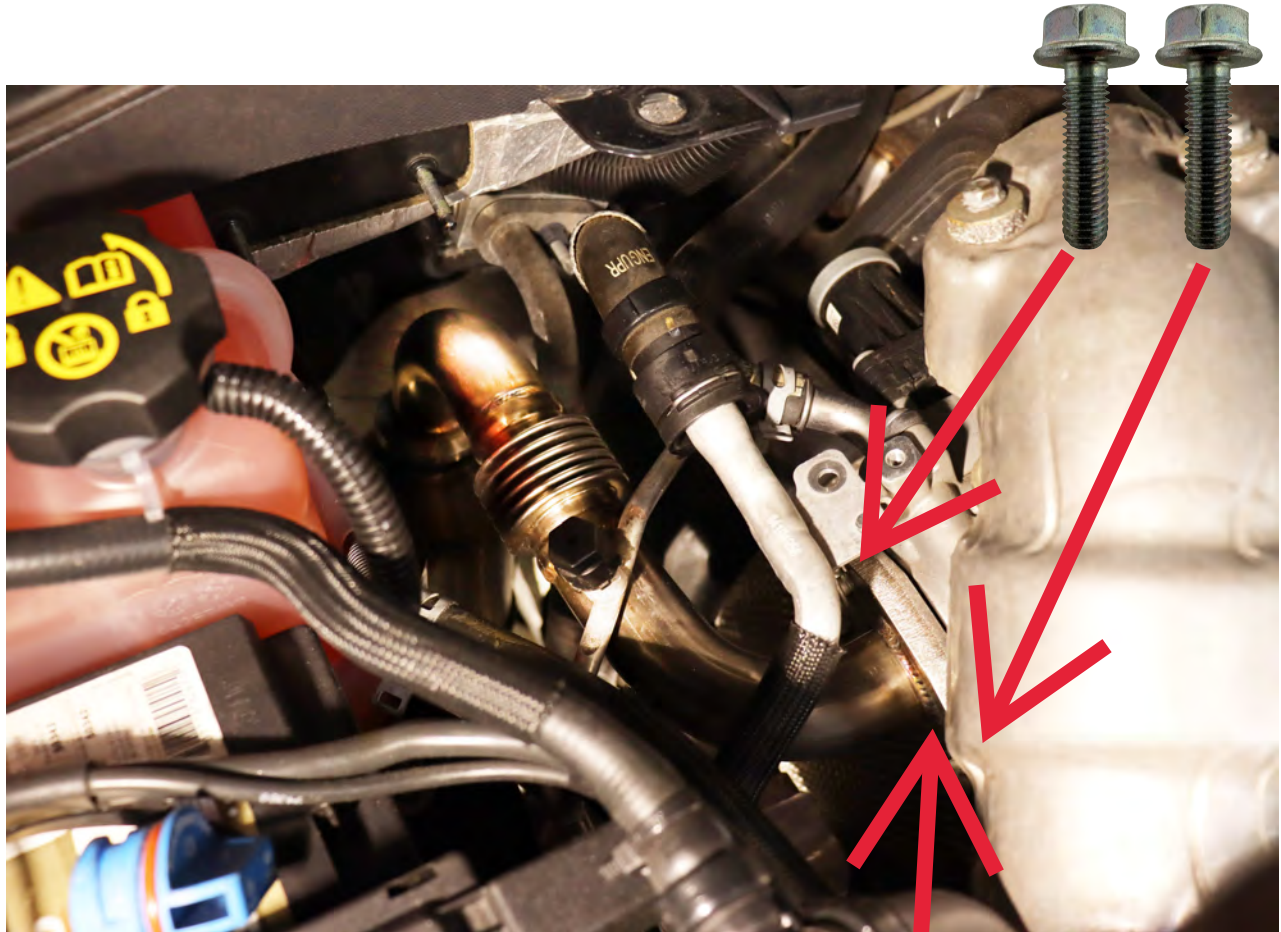

9. Tighten the hardware below in sequence:

- 1. Tighten the filter inlet V-band clamp.**
- 2. Tighten the lower 2-bolt flange bolts.**
- 3. Tighten the upper V-band clamp on the filter outlet.**
- 4. Tighten the upper 2-bolt flange bolts.**



10. Loosely install the EGR filter mounting bracket 2024-GMBRCKT onto the open threaded boss on the exhaust manifold using the supplied M10x30mm flange bolt PN. 11115733. DO NOT TIGHTEN AT THIS TIME.

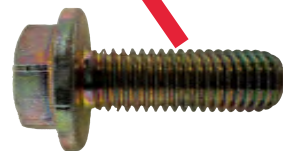

11. Using the supplied T-bolt clamp PN. CLA000105, clamp the EGR filter to the bracket and tighten accordingly. Tighten the mounting bracket bolt accordingly.



12. Remove the wire harness from the mounting clip as shown.

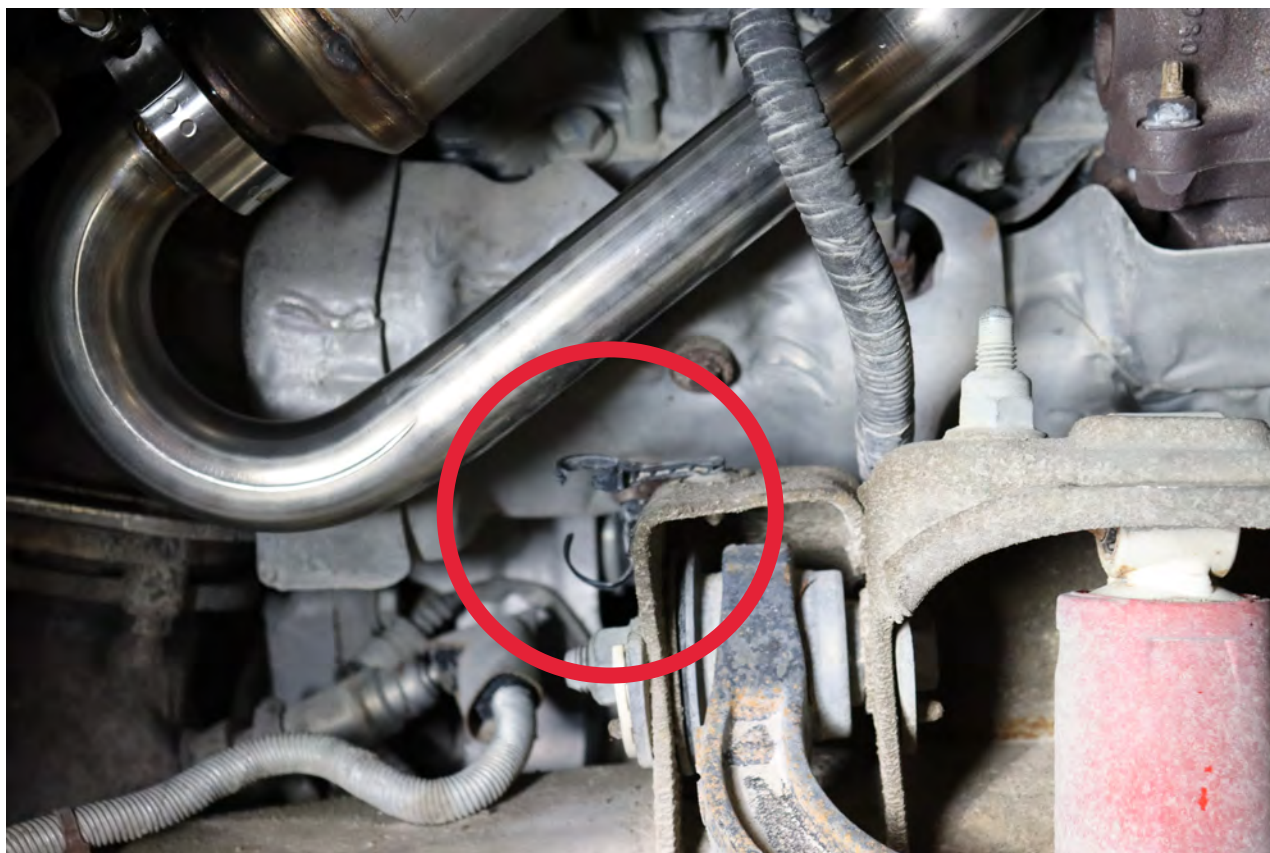

13. Position the wire harness away from the EGR tube as shown, then secure to the AC line using a cable tie.

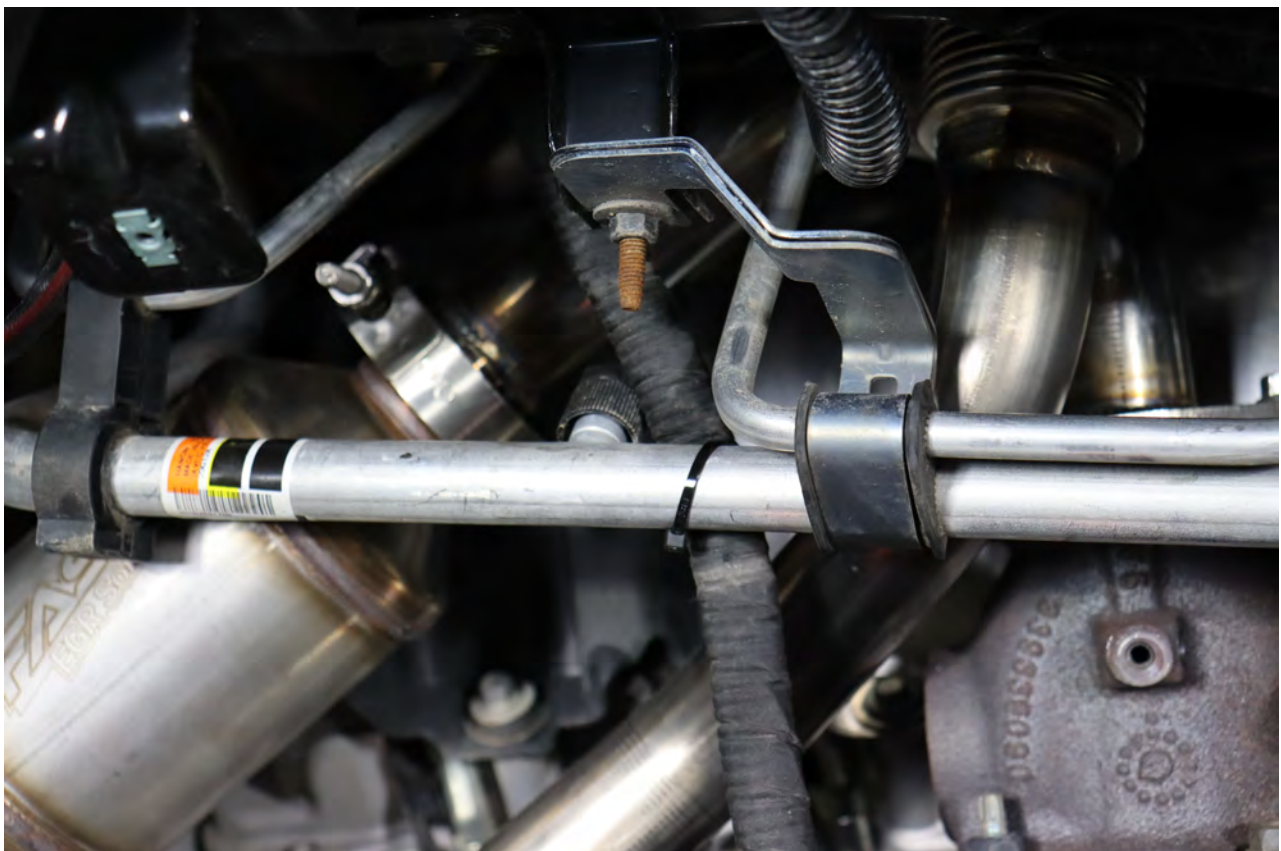
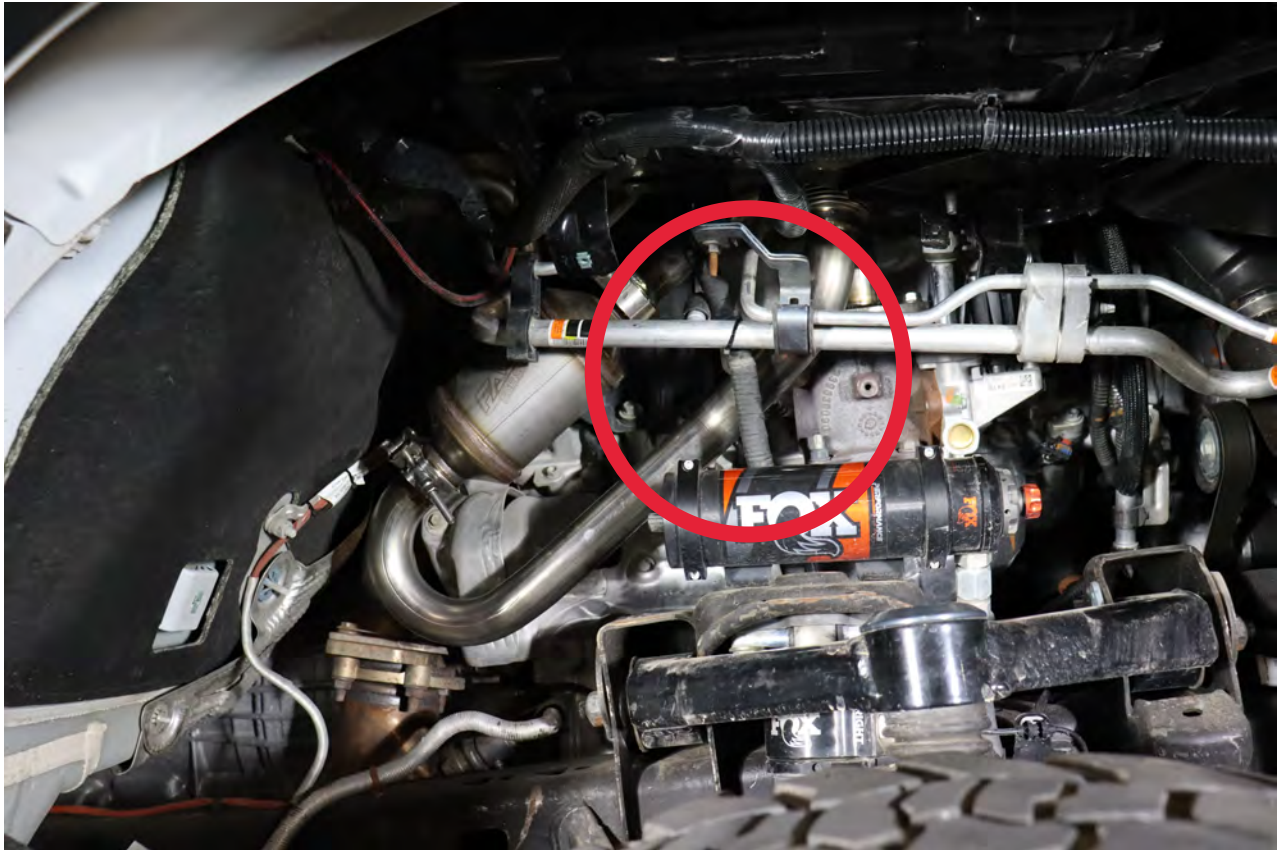

14. Secure the wire away from the EGR filter components with cable ties as shown.

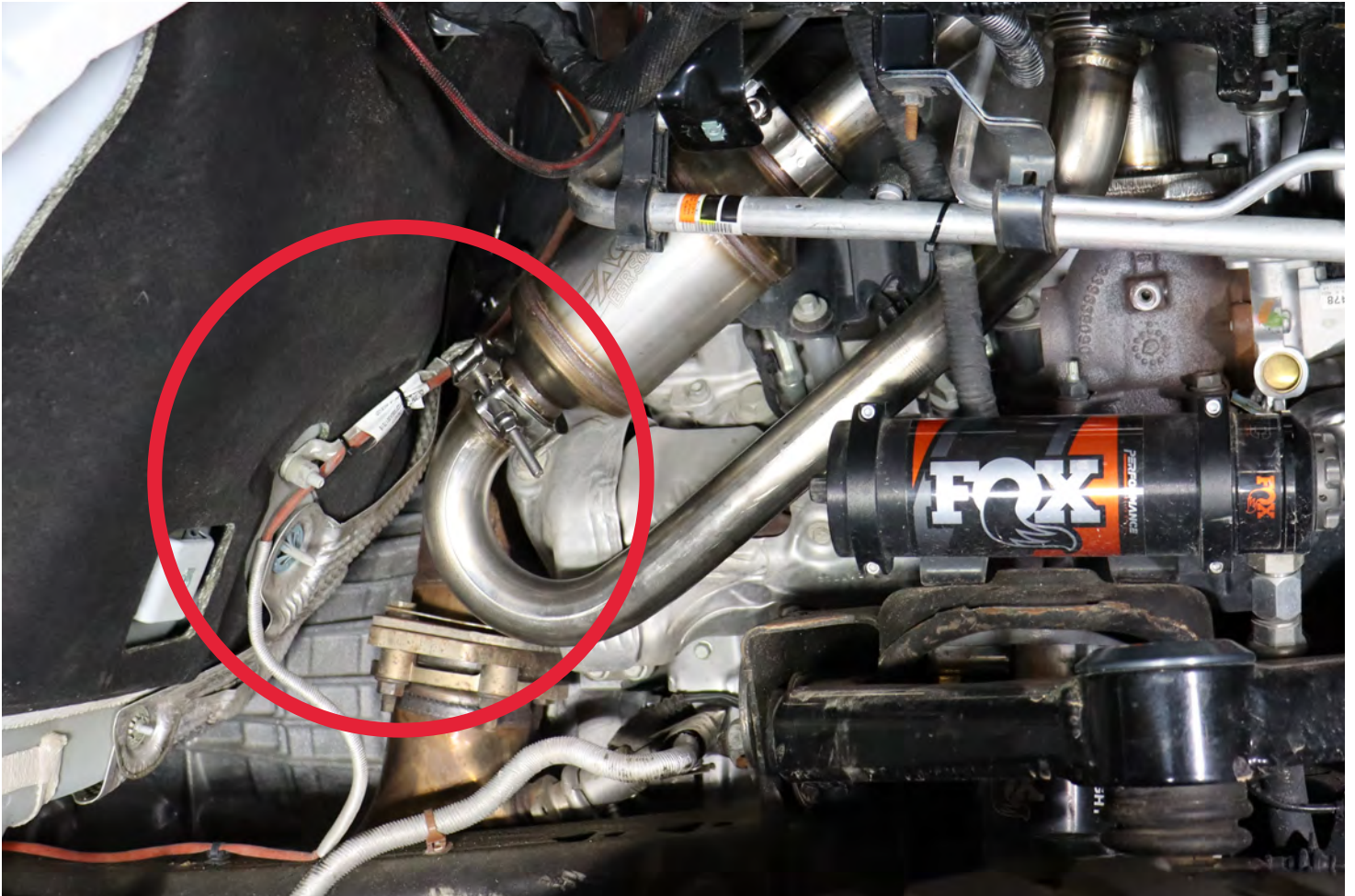

15. Start the truck with the fender liner removed and check for leaks. Let the engine warm up, then have someone lightly rev the engine multiple times while watching for soot or any other visible leaks or exhaust odor.



**16. Reinstall the passenger side fender liner and wheel/tire assembly.
Torque the lug nuts to OEM specification.**

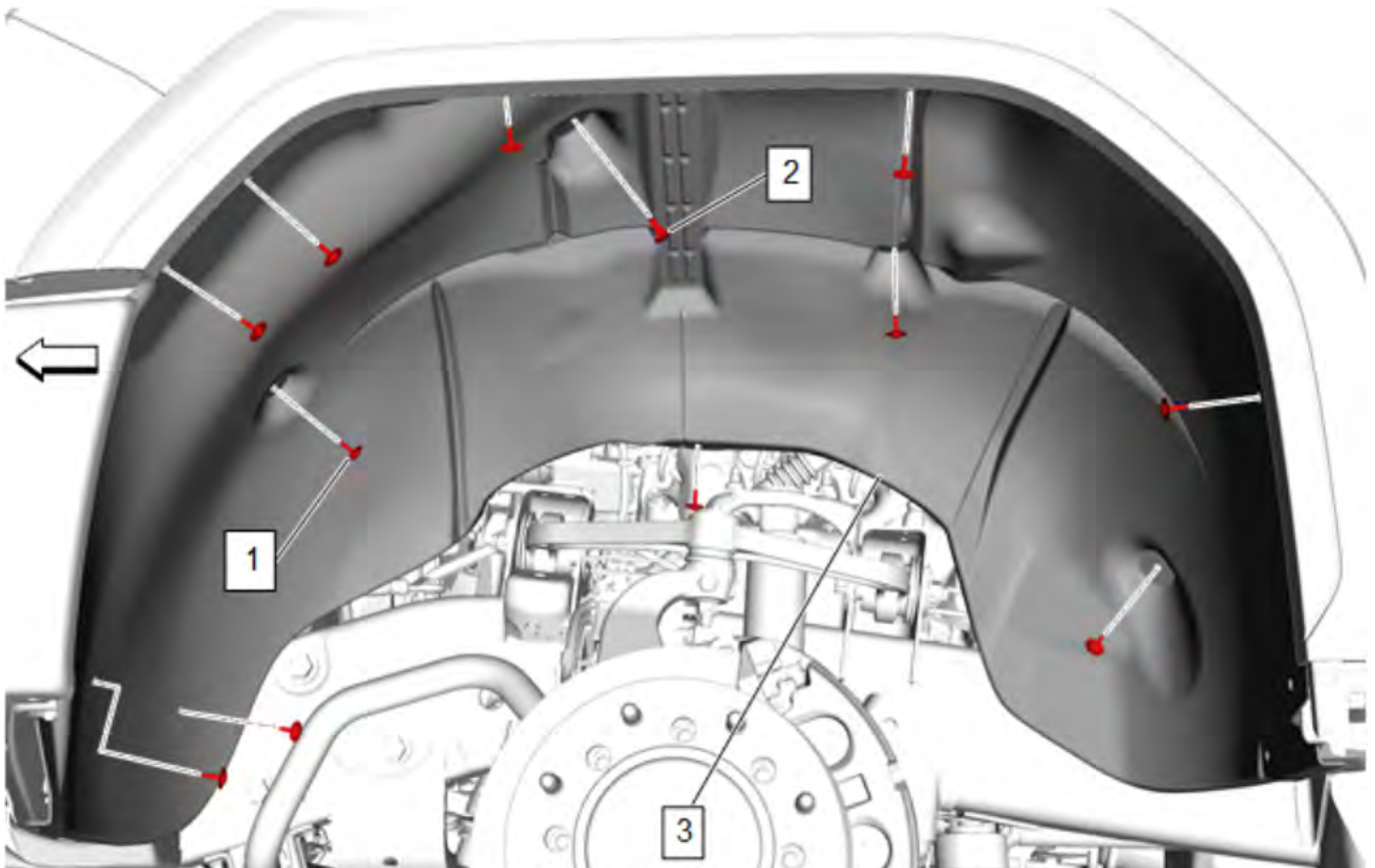
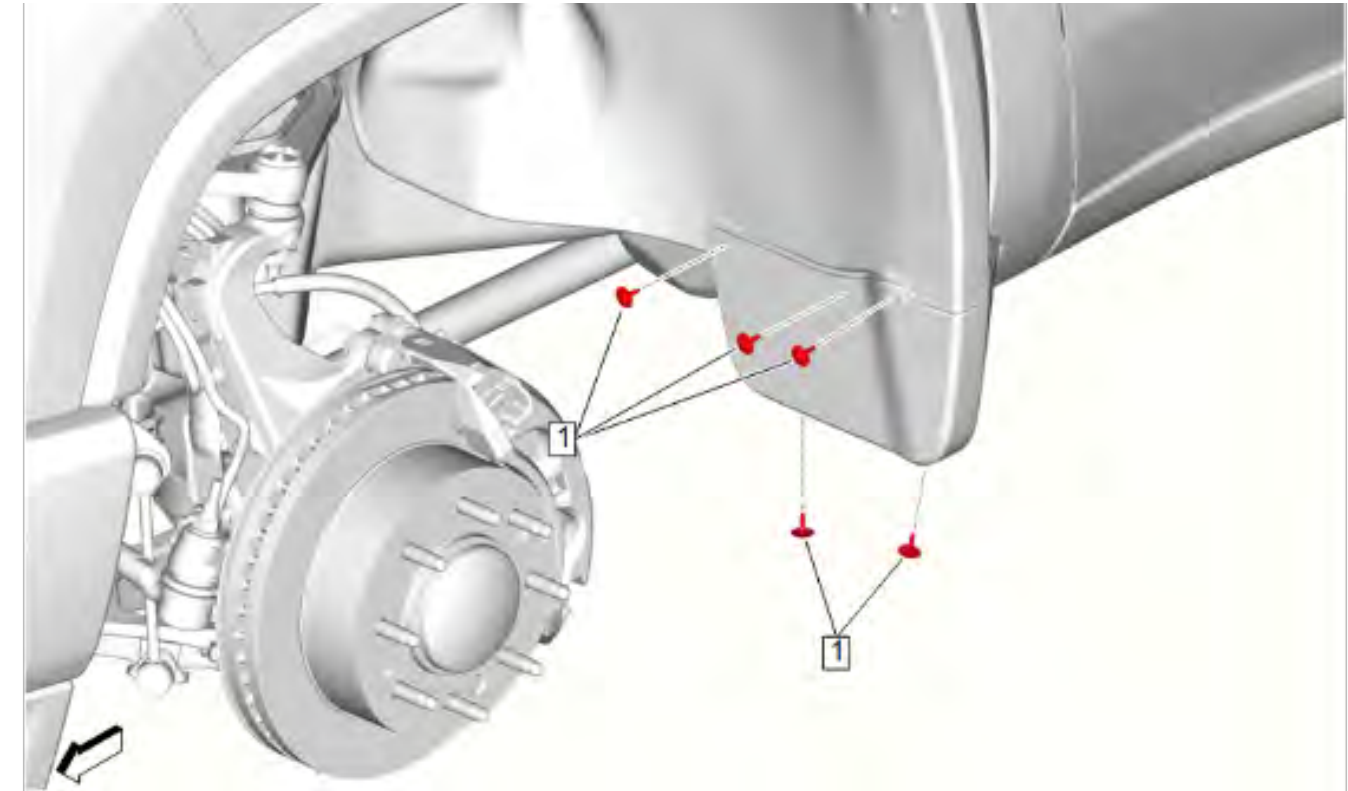



LIMITATION OF ONE YEAR WARRANTY

Disclaimer: To help ensure you receive the proper system and customer support at the local level, FASS has a VIP and Authorized Dealer network representing FASS products. This is one reason you must purchase through a dealer to comply with our warranty policies. If you do not, there is no warranty! We recommend you go to www.FASSegr solutions.com, click "Find a Dealer", put in their ZIP code, select the type of dealer, and see if the company you purchased from is listed. If they are not, put their phone number in the field below the ZIP code field to see if they are listed. Below these two fields is a list of "Terminated/Unauthorized" dealers. You may want to review this list. If the company is not listed or is on the "Terminated/Unauthorized" list, we suggest you return the product immediately to that dealer and call FASS. We'll recommend you to the nearest dealer.

Diesel Performance Products, Inc. (hereafter "SELLER") gives Limited Warranty as to description, quality, merchantability, fitness for any product's purpose, productiveness, or any other matter of SELLER'S product sold herewith. The SELLER shall be in no way responsible for the product's open use and service and the BUYER hereby waives all rights other than those expressly written herein. This Warranty shall not be extended or varied except by a written instrument signed by SELLER and BUYER.

When MANUFACTURER receives the "ORIGINAL" PRODUCT REGISTRATION form with a copy of the "BILL OF SALE/SALES RECEIPT" within 30 days of the sale, then the following applies! The Warranty will then and only then be validated to that of which typically accompanies your unit for your specific application from the date of sale or for recommended service life and limited solely to the original purchaser and/or vehicle and parts contained within the product's kit. This warranty does not cover normal wear on consumable items such as but not limited to filters, fuel line, wire harness & etc. The warranty does not cover seized gears due to lack of filtration. Warranty is voided if used with other than diesel fuel. Returned items will arrive prepaid to the place of purchase. Diesel Performance Products, Inc. will repair, without cost, any product found to be defective during the warranty period; parts only, or at its option, will replace such products in exchange for the product. Repair or replacements are warranted for the remainder of the original warranty period. All Warranty claims are subject to approval by Diesel Performance Products, Inc.

A Return Material Authorization (RMA) number must be obtained before any product is to be returned to Diesel Performance Products, Inc. for warranty consideration, repair or product return. Requests for product returns must be offset by an equal value order. Return parts must be completed and in resalable condition. No returns after 30 days.

Your Name, Address, and Phone Number's

Model and Serial Number (Not Motor Number) Example: Model HD Series, Serial: 00125966 VIN Number of Vehicle

Date of Purchase

Nature of Problem

RMA and Product Serial Number must be on all paperwork and correspondence. Failure to obtain the required information or paperwork will result in \$25.00/item penalty and delay or denial of any warranty claim.

Under no circumstances shall the SELLER and/or MANUFACTURER be liable for any labor charged or travel time incurred in diagnosis for defects, removal, or reinstallation of this product, or any other contingent expenses.

Under no circumstances shall the SELLER and/or MANUFACTURER be liable for any damage or expenses insured by reason of the use or sale of any such equipment. This warranty does not apply to products which Diesel Performance Products, Inc. has determined to have been misused or abused, improperly maintained by the user, or where the malfunction or defect can be attributed to the use of non-genuine Diesel Performance Products, Inc. parts.

IN THE EVENT THAT THE BUYER DOES NOT AGREE WITH THIS AGREEMENT: THE BUYER MAY PROMPTLY RETURN THIS PRODUCT, IN A NEW AND UNUSED CONDITION, WITH A DATED PROOF OF PURCHASE, TO THE PLACE OF PURCHASE WITHIN THIRTY (30) DAYS FROM DATE OF PURCHASE FOR A FULL REFUND LESS SHIPPING.

THE INSTALLATION OF THIS PRODUCT INDICATES THAT THE BUYER HAS READ AND UNDERSTANDS THIS AGREEMENT AND ACCEPTS ITS TERMS AND CONDITIONS.